

**Размеры мест под гаечные ключи  
ГОСТ 13682-80**

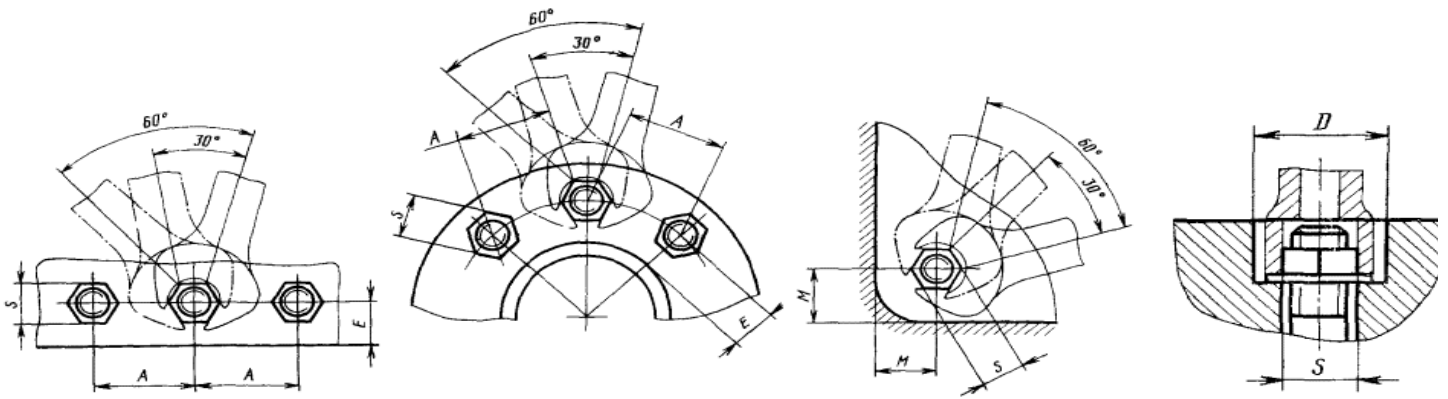

Резьба	Зев ключа	Расстояние между гайками	Расстояние в углу	Диаметр отв. под торцевой ключ
M	S	A	M	D
M1,6	3,2	8	5	11
M2	4	9	5	12
M2,5	5	11	7	14
M3	5,5	12	7	14
M4	7	14	8	16
M5	8	17	9	20
M6	10	20	11	22
M7(DIN)	11			
	12	24	13	26
M8	13	26	14	26
	14	28	15	26
M10	16			
M10(DIN)	17	34	17	30
M12	18			
M12(DIN)	19	36	19	32
M14	21			
M14(DIN)	22	42	24	36
M16	24	48	25	40
M18	27	52	28	45
M20	30	8	30	48
M22(DIN)	32	62	32	52
M22	34			
M24	36	68	36	60
M27	41	80	40	63
M30	46	90	45	70
M33(DIN)	50	95	48	75
M36	55	105	52	85
M39(DIN)	60	110	55	95
M42	65	120	60	98
M45(DIN)	70	130	65	105
M48	75	140	70	110
M52	80	150	75	
M56	85	160	82	
M60(DIN)	90	170	88	
M64	95	175	92	
M68(DIN)	100	190	98	
M72	105	200	102	
M76	110	205	105	
M80	115	215	110	
M90	130	245	120	
M100	145	275	140	
M110	155	295	150	
	175	330	165	
M125	180	335	170	
	185	345	175	
M140	200	370	180	
	210	395	205	
M150	225	420	220	