

1. Scope

This document specifies studs with a screw thread length side of about $2,5d$ in product grade A with metric thread M4 to M24 metric fine thread M8x1 to M24x2 of proof.

Studs according to this standard are primarily used for screwing in light metals with low strengths used.

2. Normative References

The following referenced documents are indispensable for the application of this document. For dated references, only the edition cited applies. For undated references the latest edition of the referenced document (including any amendments).

DIN 13-51

DIN 267-2

DIN 962

DIN EN 26157-3

DIN EN ISO 225

DIN EN ISO 898-1

DIN EN ISO 3269

DIN EN ISO 4042

DIN EN ISO 4753

DIN EN ISO 4759-1

DIN ISO 261

DIN ISO 965-1

DIN ISO 8992

3. Dimensions

See Figure 1 and Table 1

Dimensional letters and their description are defined in DIN EN ISO 225.

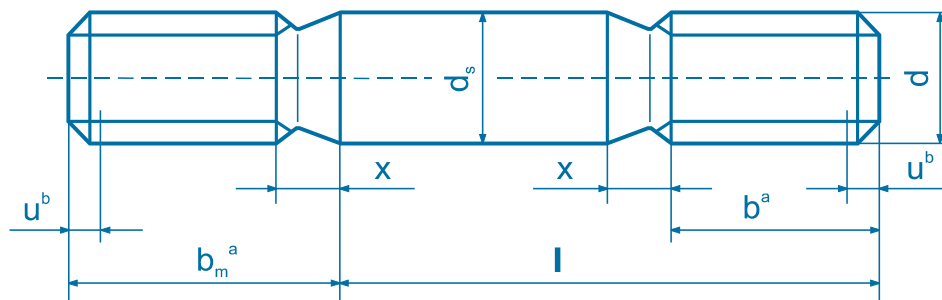

^a For performance and labeling of the threaded ends, see explanation in Table 1

^b $u \leq 1,5 P$

Figure 1 - Stud - Example with threaded end FL to DIN EN ISO 4753

Table 1 - Dimensions

Dimensions in mm

Thread size (<i>d</i>)	M4	M5	M6	(M7)	M8	M10	M12	(M14)	M16	(M18)	M20	(M22)	M24	
	-	-	-	-	M8 x 1	M10 x 1,25	M12 x 1,25	(M14 x 1,5)	M16 x 1,5	(M18 x 1,5)	M20 x 1,5	(M22 x 1,5)	M24 x 2	
<i>b_m</i>	10	13	15	18	20	25	30	35	40	45	50	55	60	
<i>b</i>	a	14	16	18	20	22	26	30	34	38	42	46	50	54
	b	20	22	24	26	28	32	36	40	44	48	52	56	60
	c	-	-	-	-	-	45	49	53	57	61	65	69	73
<i>d_s</i>	max	4	5	6	7	8	10	12	14	16	18	20	22	24
	min	3,82	4,82	5,82	6,78	7,78	9,78	11,73	13,73	15,73	17,73	19,67	21,67	23,67
<i>x</i>	1,75	2,0	2,5	2,5	3,2	3,8	4,3	5,0	5,0	6,3	6,3	6,3	7,5	
<i>l</i>	Mass (7.85kg/dm ³), in kg per 1000 units													
js 15														
12														
(14)														
16														
(18)														
20	2,14													
(22)	2,61	4,46												
25	2,90	4,92	7,26											
(28)	3,20	5,38	7,93	11,8										
30	3,40	5,69	8,37	12,4	16,3									
35	3,89	6,46	9,48	13,9	18,3	30,7								
40	4,38	7,23	10,6	15,4	20,2	33,8	51,9							
45		8,00	11,7	16,9	22,2	36,9	56,3	80,9						
50		8,77	12,8	18,4	24,2	39,9	60,8	86,9	122					
55			13,9	20,0	26,2	43,0	65,2	93,0	130	167				
60			15,0	21,5	28,1	46,1	69,7	99,0	138	177	232			
65				23,0	30,1	49,2	74,1	105	146	187	244	311		
70					32,1	52,3	78,5	111	154	197	257	326	394	
75					34,1	55,4	83,0	117	161	207	269	341	412	
80					36,0	58,4	87,4	123	169	217	281	356	430	
(85)						61,5	91,9	129	177	227	294	371	447	
90						64,6	96,3	135	185	237	306	386	465	
(95)						67,7	101	141	193	247	318	401	483	
100						70,8	105	147	201	257	331	415	501	
110							114	159	217	277	355	445	536	
120							123	172	232	297	380	475	572	
130								184	248	317	405	505	607	
140								196	264	337	429	535	643	
150									280	357	454	565	678	
160									296	377	479	594	714	
170										397	503	624	749	
180										417	528	654	785	
190											553	684	820	
200											577	714	856	

Table 1 (concluded)

^a $l \leq 125$ mm.
^b 125 mm $< l \leq 200$ mm.
^c $l > 200$ mm.

Lengths over 200 mm of 20 mm to 20 mm in steps.
 Bracketed sizes as well as intermediate lengths shall be minimized.
 The standard lengths of studs with coarse thread between the solid step lines.
 Stud bolts with lengths above the upper solid line stages can not be produced with the given thread lengths b . For these studs is the thread length $b \approx l - (x + 3)$.
 For studs with lengths above the dashed step line is $b + x < 1,2 b_m$. Therefore, nut-end up with a rounded end according to DIN EN ISO 4753 must be running for these studs to distinguish the two threaded ends, if not the hallmark of strength class is attached to the end face of the nut end.

4. Technical delivery conditions

Table 2: Technical delivery conditions

Material		Steel	
General requirements		As specified in ISO 8992	
Thread	Tolerance class	Screw-sided thread ^a Sk 6, Sn 4	Nut-sided: 6g
	Standard	DIN 13-51	DIN ISO 261 and DIN ISO 965-1
Mechanical properties	Property class (material) ^b	5.6, 8.8	
	Standard	DIN EN ISO 898-1	
Limit deviations and geometrical tolerances	Product grade	A	
	Standard	DIN EN ISO 4759-1	
Surface	Strength class 5.6: prepared as. Strength class 8.8: blackened (thermal or chemical). For the surface roughness DIN 267-2. DIN EN 26157-3 applies to the limiting values of surface defects. For galvanized surface protection to DIN EN ISO 4042 applies. The set for the thread thread limit dimensions apply after applying a coating.		
Acceptance inspection	As specified in DIN EN ISO 3269		

^a For the screw thread side applies to DIN 267-2, the tolerance class Sk 6, if not in the description (see Section 5) Fo (= without interference thread) or Sn 4 is specified.
^b Other strength classes or materials on request.

5. Designation

Designation of a stud with hard seat and screw thread M12 sided thread tolerance class Sk 6, nominal length $l = 80$ mm and property class 8.8:

Stud DIN 940 - M12 x 80 – 8.8

Designation of a stud with interference thread M12 x 1.25 and Screw-sided thread tolerance class Sn 4, nominal length $l = 80$ mm and property class 8.8:

Stud DIN 940 - M12 x 1.25 Sn 4 x 80 – 8.8

Designation of a stud bolt with thread M12 without interference thread (Fo), nominal length $l = 80$ mm and property class 8.8:

Stud DIN 940 - M12 Fo x 80 – 8.8

If the studs are screwing each other and nut side supplied with different thread pitches, so this must be indicated in the name, in the order the Screw-page thread has to be mentioned first, for example:

Stud DIN 940 - M12 - M12 x 1,25 x 80 – 8.8

DIN is valid for the description of shapes and designs with additional ordering information 962.

note: настоящий файл предназначен только для ознакомления. используйте в работе только официальные издания. данный файл принадлежит компании Восток-Интер www.vostok-inter.uaprom.net при размещении этого файла на других ресурсах прямая ссылка на сайт компании Восток-Интер обязательна. Если вы нашли ошибку или неточность в тексте, пожалуйста, сообщите нам любым удобным способом.