

Prevailing torque type hexagon domed cap nuts with nonmetallic insert

DIN
986

Sechskant-Hutmuttern mit Klemmteil, mit nichtmetallischem Einsatz

Supersedes September 1977 edition.

In keeping with current practice in standards published by the International Organization for Standardization (ISO), a comma has been used throughout as the decimal marker.

Dimensions in mm

1 Field of application

This standard specifies requirements for M 4 to M 20 prevailing torque type hexagon domed cap nuts with non-metallic insert, assigned to product grade A for sizes up to M 16 and product grade B for size M 20.

If, in special cases, nuts are to comply with specifications other than those given in this standard, e.g. regarding materials other than specified in DIN 267 Part 15, performance at temperatures exceeding + 120 °C, or corrosion resistance, this shall be agreed at the time of ordering (cf. DIN 267 Part 15).

2 Dimensions

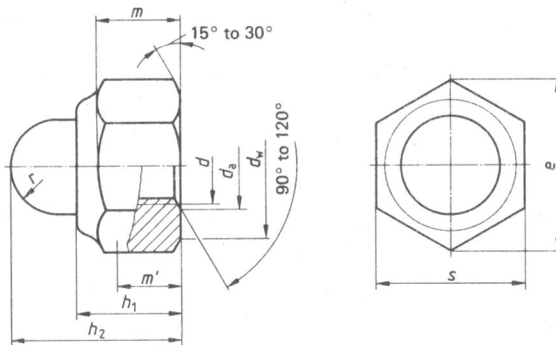

m' = minimum wrenching height.

Continued on pages 2 to 4

Thread size	M 4	M 5	M 6	M 8	M 10	M 12	M 14	M 16	M 20				
	-	-	-	M 8 × 1	M 10 × 1	M 12 × 1,5	M 14 × 1,5	M 16 × 1,5	M 20 × 2				
	-	-	-	-	M 10 × 1,25	M 12 × 1,25	-	-	M 20 × 1,5				
P ¹⁾	0,7	0,8	1	1,25	1,5	1,75	2	2	2,5				
d _a	min.	4	5	6	8	10	12	14	16	20			
	max.	4,6	5,75	6,75	8,75	10,8	13	15,1	17,3	21,6			
d _w min.	5,9	6,9	8,9	11,6	15,6	17,4	20,5	22,5	27,7				
e min.	7,66	8,79	11,05	14,38	18,9	21,1	24,49	26,75	32,95				
	nominal size	5,6	6	7,5	8,9	10,5	13,5	15,5	16,5	21			
h ₁	max.	5,85	6,25	7,85	9,25	10,9	13,9	15,9	16,9	21,5			
	min.	5,35	5,75	7,15	8,55	10,1	13,1	15,1	16,1	20,5			
h ₂	nominal size	9,6	10,5	12	14	18,1	22,5	26,4	27,5	35			
	max.	9,9	10,85	12,35	14,35	18,5	22,9	26,8	27,9	35,5			
	min.	9,3	10,15	11,65	13,65	17,7	22,1	26	27,1	34,5			
m min. ²⁾	2,9	4,4	4,9	6,44	8,04	10,37	12,1	14,1	16,9				
m' min.	2,32	3,52	3,92	5,15	6,43	8,3	9,68	11,28	13,52				
r	nominal size	2,5	3	3,5	4,6	5,8	6,8	7,8	8,8	10,8			
	max.	2,7	3,5	4	5,1	6,3	7,8	8,8	9,8	11,8			
	min.	2,3	2,5	3	4,1	5,3	5,8	6,8	7,8	9,8			
s	max. = nominal size	7	8	10	13	16 ³⁾	17	18 ³⁾	19	21 ³⁾	22	24	30
	min.	6,78	7,78	9,78	12,73	15,73	16,73	17,73	18,67	20,67	21,67	23,67	29,16

1) P = pitch of coarse thread as specified in DIN 13 Part 15.
2) Also minimum thread length.
3) See clause 5.

3 Technical delivery conditions

Material		Steel
General requirements		As specified in DIN 267 Parts 1 and 15.
Thread	Tolerance	6H ¹⁾
	As specified in	DIN 13 Part 15.
Mechanical properties (nut body)	Property class (material)	5, 6 ²⁾ , 8 or 10. Cap: sheet steel.
	As specified in	ISO 898 Part 2 and DIN 267 Part 15.
Material (insert)		Nonmetallic, e.g. polyamide
Limit deviations and geometrical tolerances	Product class	For sizes up to M 16: A. For sizes over M 16: B.
	As specified in	ISO 4759 Part 1.
Surface finish		As processed. DIN 267 Part 2 shall apply with regard to surface roughness. DIN 267 Part 20 shall apply with regard to permissible surface discontinuities. DIN 267 Part 9 shall apply with regard to electroplating.
Acceptance inspection		DIN 267 Part 5 shall apply with regard to acceptance inspection.
1) See also DIN 267 Part 15.		
2) Applies only to nuts with fine pitch thread.		

Note. Tolerance class 6H shall apply for the thread of nuts with and without coating. Where a protective coating is applied, e.g. an electroplated coating complying with DIN 267 Part 9, depending on the coating thickness required, it may be necessary to select a larger fundamental deviation than that assigned to the H position (see DIN 267 Part 9). This, however, might impair the resistance of the bolt/nut assembly to stripping.

4 Mass

The values of mass are given for guidance only.

Thread size	M 4	M 5	M 6	M 8	M 10		M 12		M 14		M 16	M 20
Width across flats, s	7	8	10	13	16	17	18	19	21	22	24	30
Mass (7,85 kg/dm ³) for 1000 units, in kg, ≈.	1,4	1,55	3,3	5,3	10,1	10,7	18,3	19	26,1	26,8	37,1	111

Approximately the same values can be assumed for fine thread nuts.

5 Designation

Designation of an M 12 prevailing torque type hexagon domed cap nut with nonmetallic insert, assigned to property class 5:

Domed cap nut DIN 986 – M 12 – 5

Where nuts of sizes M 10, 12 and 14 are required to be supplied with the new widths across flats 16 mm, 18 mm or 21 mm (as specified in ISO 272), the width across flats (SW) shall be included in the designation, e.g.:

Domed cap nut DIN 986 – M 12 – SW 18 – 5

The DIN 4000 – 2 – 7 tabular layout of article characteristics shall apply for nuts covered in this standard.

6 Marking

Nuts shall be marked in accordance with DIN 267 Part 15.

Standards referred to

DIN 13 Part 15	ISO metric screw threads; fundamental deviations and tolerances for screw threads of 1 mm diameter and larger
DIN 267 Part 1	Fasteners; technical delivery conditions; general requirements
DIN 267 Part 2	Fasteners; technical delivery conditions; types of finish and dimensional accuracy
DIN 267 Part 5	Fasteners; technical delivery conditions; acceptance inspection (modified version of ISO 3269, 1984 edition)
DIN 267 Part 9	Fasteners; technical delivery conditions; electroplated components
DIN 267 Part 15	Fasteners; technical delivery conditions; prevailing torque type nuts
DIN 267 Part 20	Fasteners; technical delivery conditions; surface discontinuities on nuts
DIN 4000 Part 2	Tabular layout of article characteristics for bolts, screws and nuts
ISO 272	Fasteners; hexagon products; widths across flats
ISO 898 Part 2	Mechanical properties of fasteners; nuts with specified proof load values
ISO 4759 Part 1	Tolerances for fasteners; bolts, screws and nuts with thread diameters $\geq 1,6$ and ≤ 150 mm and product grades A, B and C

Previous editions

DIN 986: 07.51, 05.56, 10.60, 11.63, 09.77.

Amendments

The following amendments have been made to the September 1977 edition.

- a) The title of the standard has been changed.
- b) The new widths across flats 16 mm, 18 mm and 21 mm have been included additionally for sizes M 10, M 12 and M 14.
- c) The text of the standard has been harmonized with the new DIN Standards on prevailing torque type hexagon nuts (DIN 6924 to DIN 6927), which are based on international standards.
- d) Some dimensions for nuts have been changed; limit deviations calculated from the permissible tolerances have been included.
- e) The technical delivery conditions have been supplemented and harmonized with Standards DIN 6924 to DIN 6927.
- f) The new property classes involving higher proof loads (as specified in ISO 898 Part 2) have been adopted instead of those specified in DIN 267 Part 4.
- g) For thread size M 20, product grade B has been specified instead of product grade A.

Explanatory notes

After the publication of DIN 986, September 1977 edition, new national and international standards on prevailing torque type nuts have been issued. These standards are based on proof loads higher than those specified in ISO 898 Part 2, and these have been adopted for the prevailing torque type nuts specified in DIN 267 Part 15.

The present standard has been revised accordingly, without changing the overall height, h_2 . The body heights (dimensions m and m'), harmonized with DIN 982 (also revised in 1987), permitted the introduction of higher proof loads as specified in ISO 898 Part 2, thus ensuring full loadability of the nuts within the specifications of ISO 898 Part 2 regarding the risk of stripping.

International Patent Classification

F 16 B 37/14